

KME Steel & Engineering

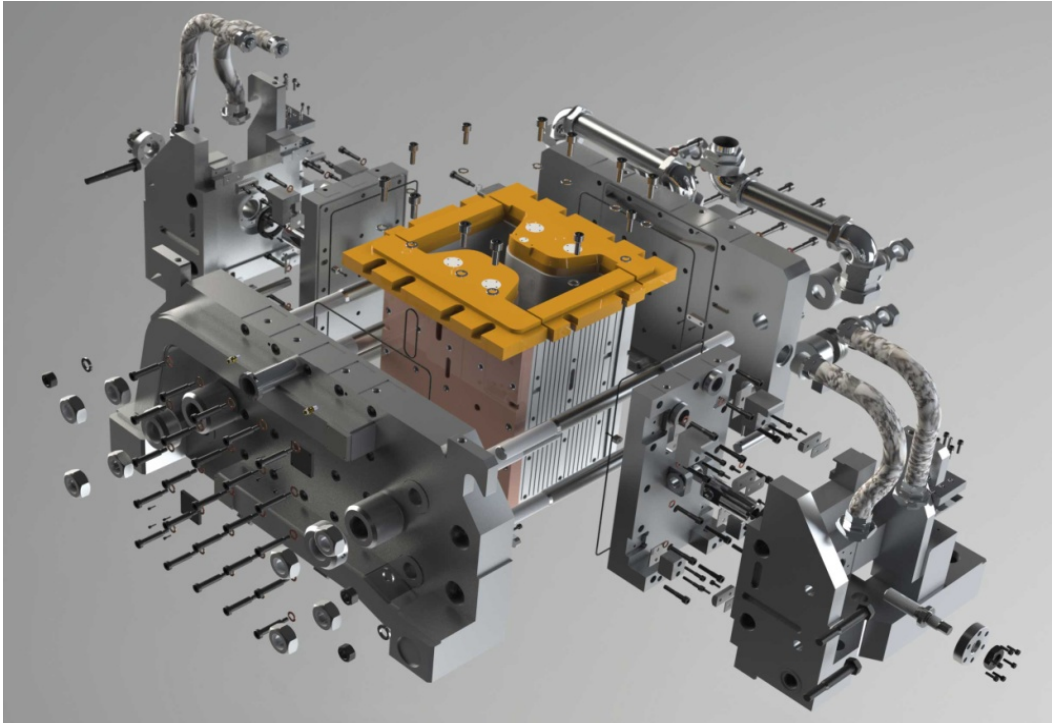

Challenge

- Revamps and improvements

Application

- All shapes, (BB, blooms, square, and round moulds)

Advantages

- Implementation of new KME design and technology

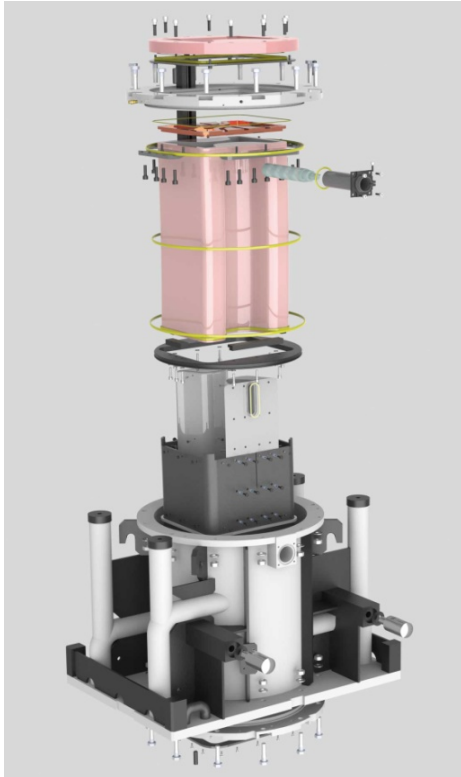

Scope of Supply

Change of mould casting size including all components

New water-jackets as Monoblock design in stainless steel

Complete CCM top blocks (incl. copper tube, water jacket, mould housing, flanges, frame, foot-rollers, spray cooling..)

New hydraulic oscillation tables, keeping amount of necessary exchange parts on low level

Change from mechanical to hydraulic oscillation tables

Spare-parts around copper tubes

Foot-rolls, dummy-bar, templates

Spray cooling area

Metallurgical studies

